

CMBP Imager

July 24, 2017

CMBP Starting Assumptions

- Medium aperture ($> \sim 1$ m) Book et al. 2009
- Reflector based
- Arrays of detectors + muxed readouts
 - baseline: multi-chroic bolometers

Imager Starting Points

- EPIC-IM and CORE
 - 1706.04516
 - 1705.02170
 - 0906.1188
 - links to papers on wiki page

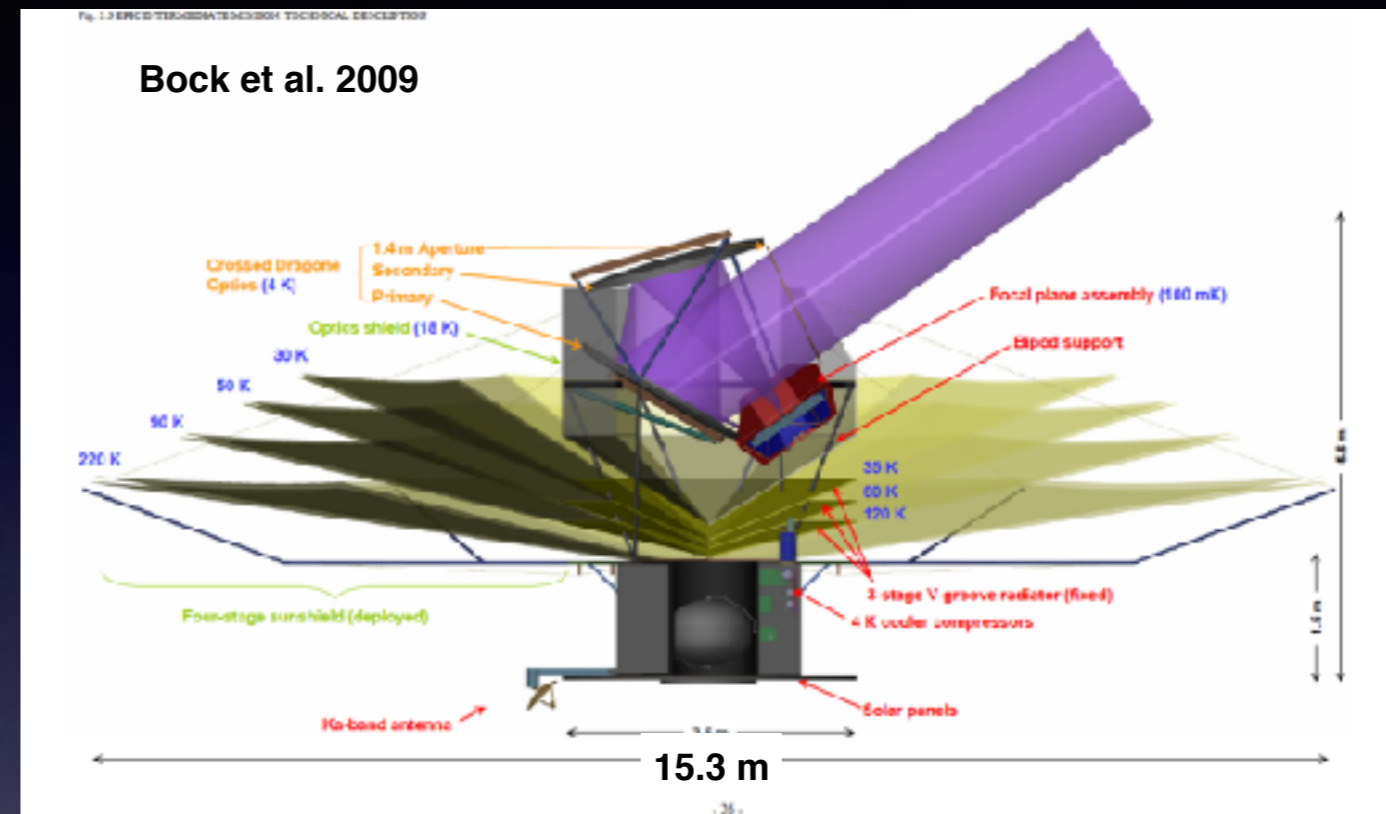

delabrouille et al. 2017

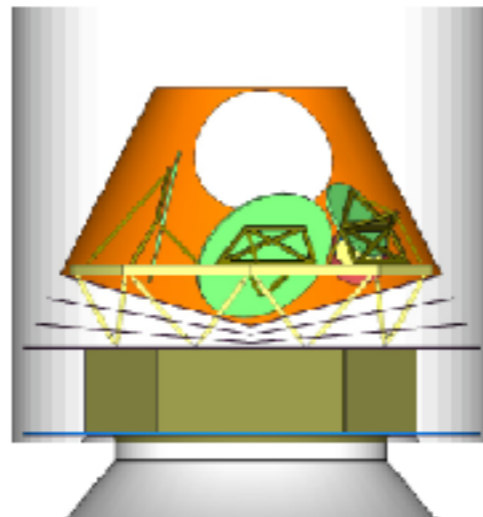
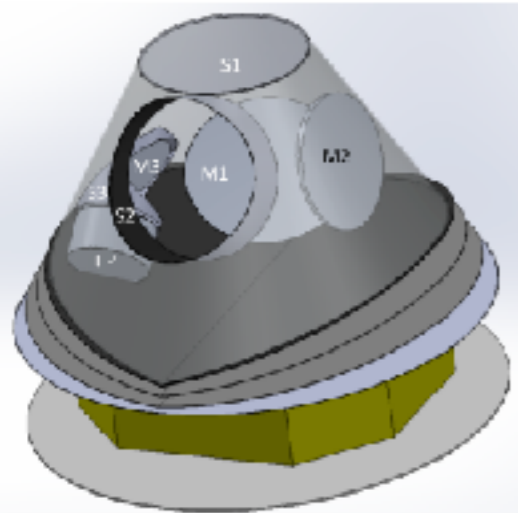

delabrouille et al. 2017

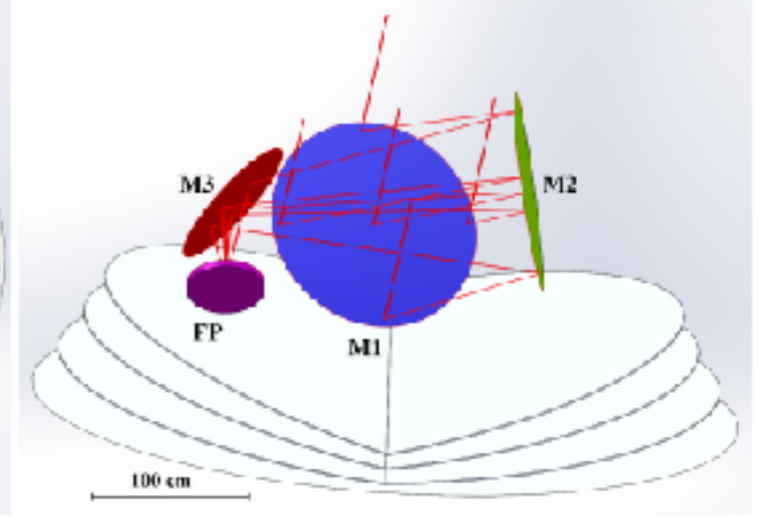
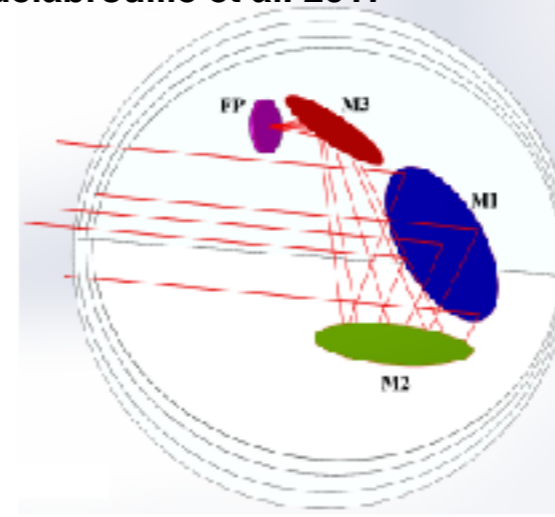

Telescope Trade-offs - I

- Three 1.2 m systems reported in CORE instrument paper
- Drivers:
 - focal plane shape and area
 - focal plane view of the sky (see slide 4)

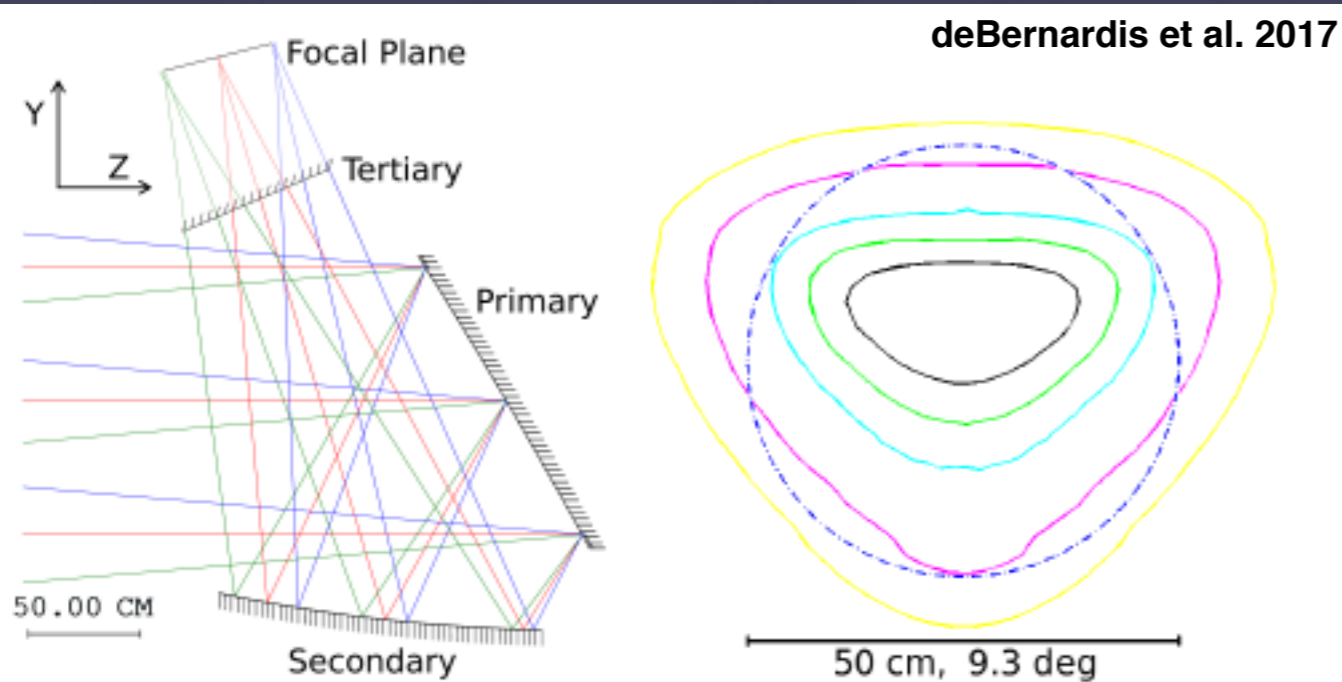
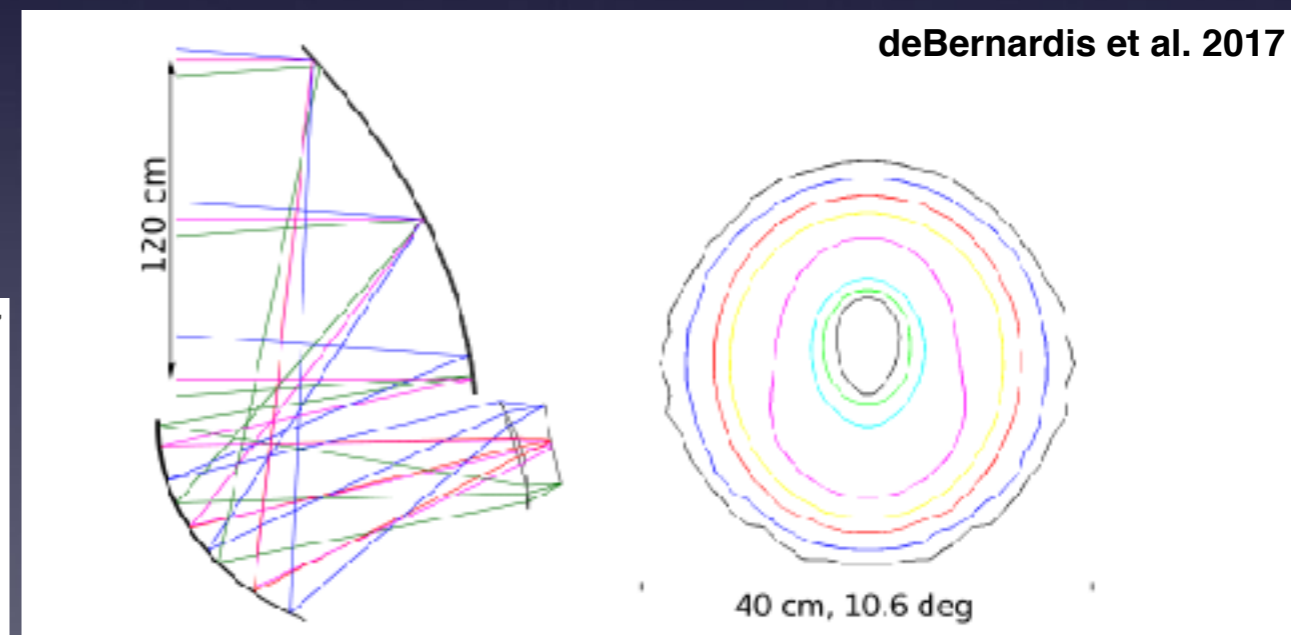
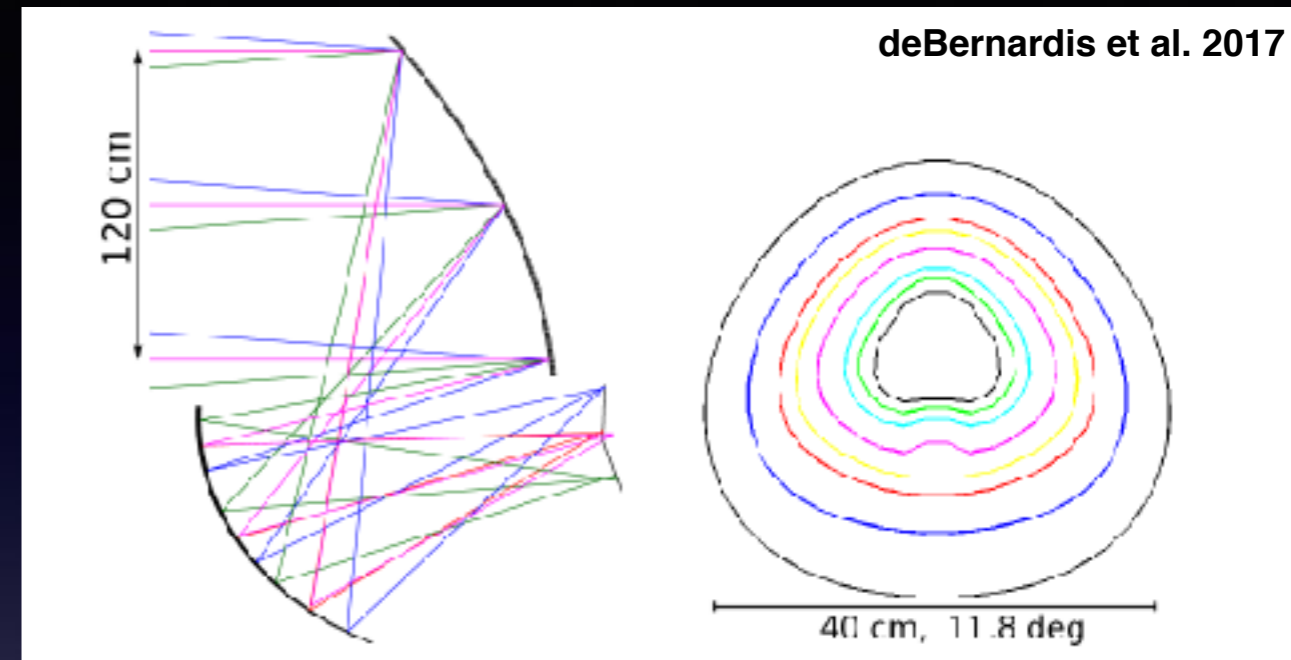

Telescope Trade-offs - II

- How important is it to avoid direct view of sky?
 - Brad is reviewing EPIC-IM analysis
- For now assuming 2-reflector crossed Dragone and 2 or 3 mirror open Dragone systems

Telescope Trade-offs - III

- Open Dragone
- Pros/Cons:
 - can baffle focal plane
 - larger reflectors -> packing challenge?

Book et al. 2009

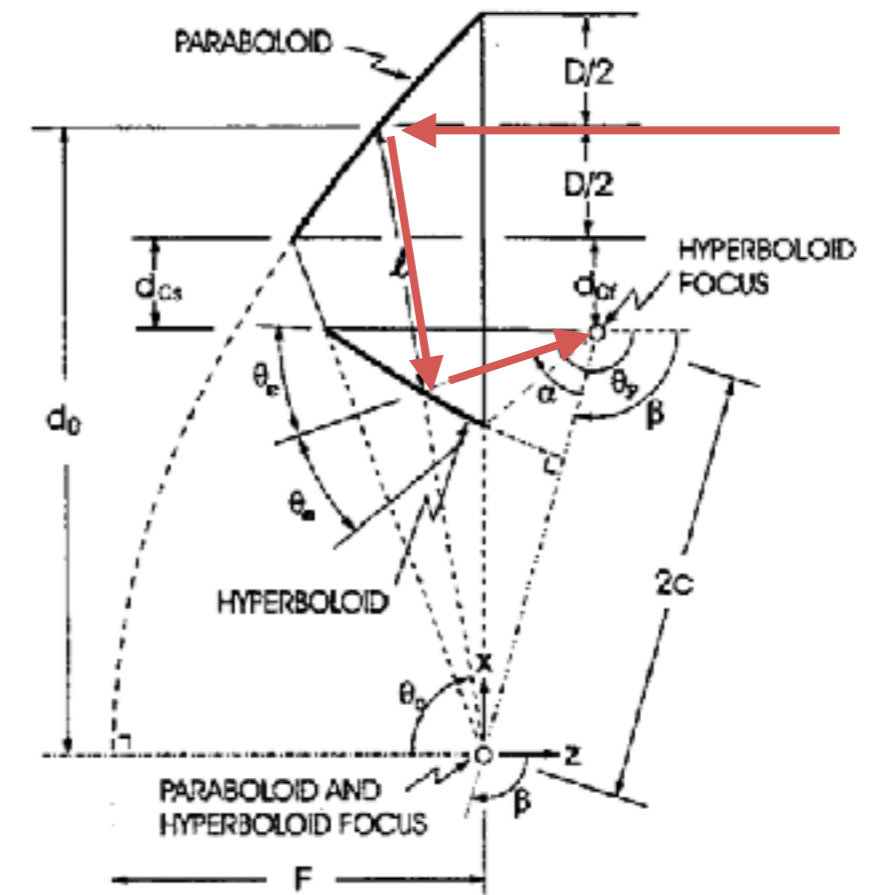
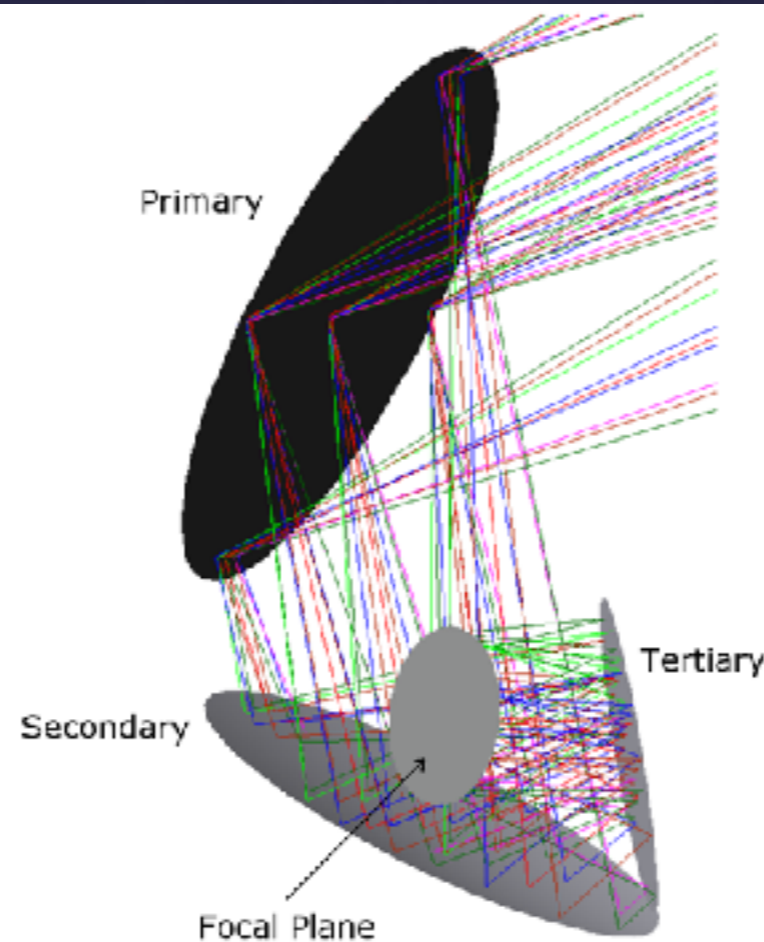
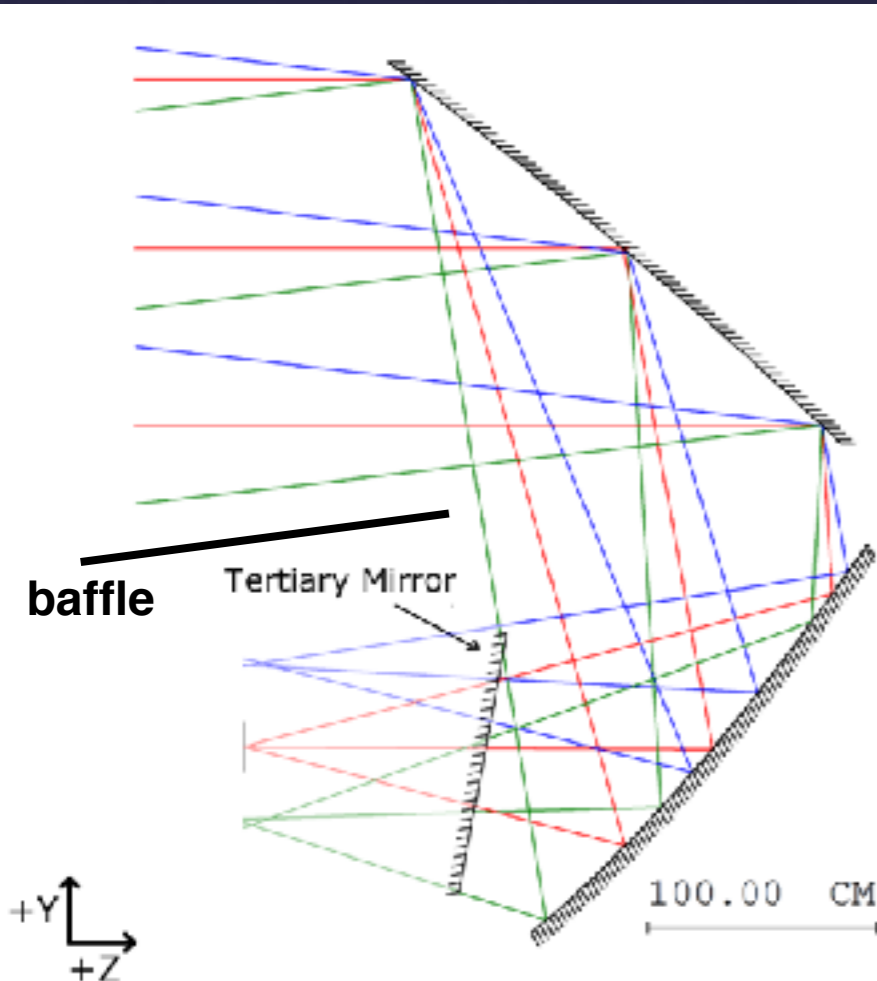

Investigation of precession angle α and spin axis-boresight angle β that fit in the payload envelope of Falcon 9

Shaul Hanany, Xin Zhi Tan, Qi Wen, Karl Young
Jul 24th, 2017

Payload Fairing

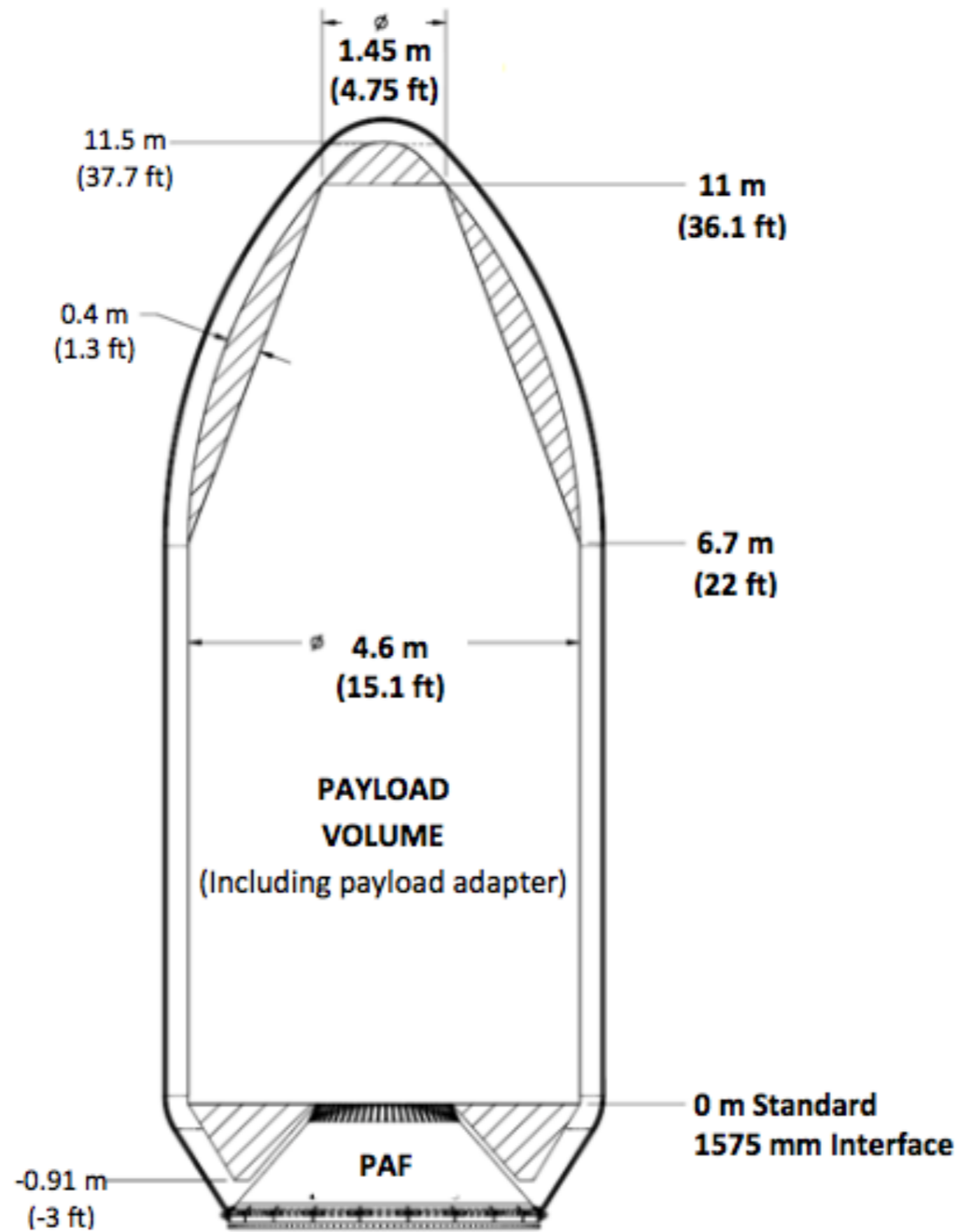
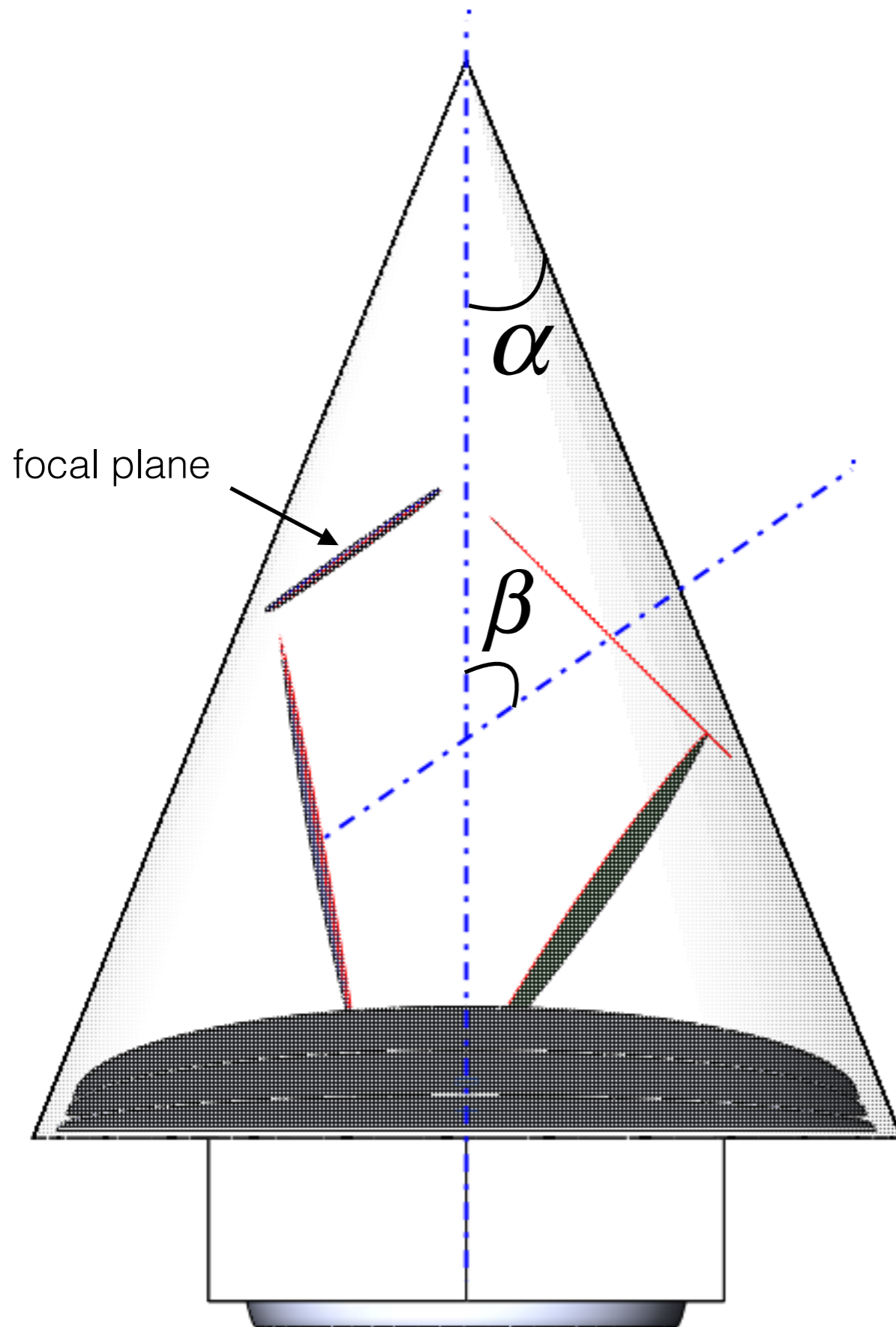

Figure 5-2: Falcon 9 fairing and payload dynamic envelope³, meters (feet)



α : angle between spin axis
and sun-spacecraft axis

β : angle between spin axis
and boresight

Background - I

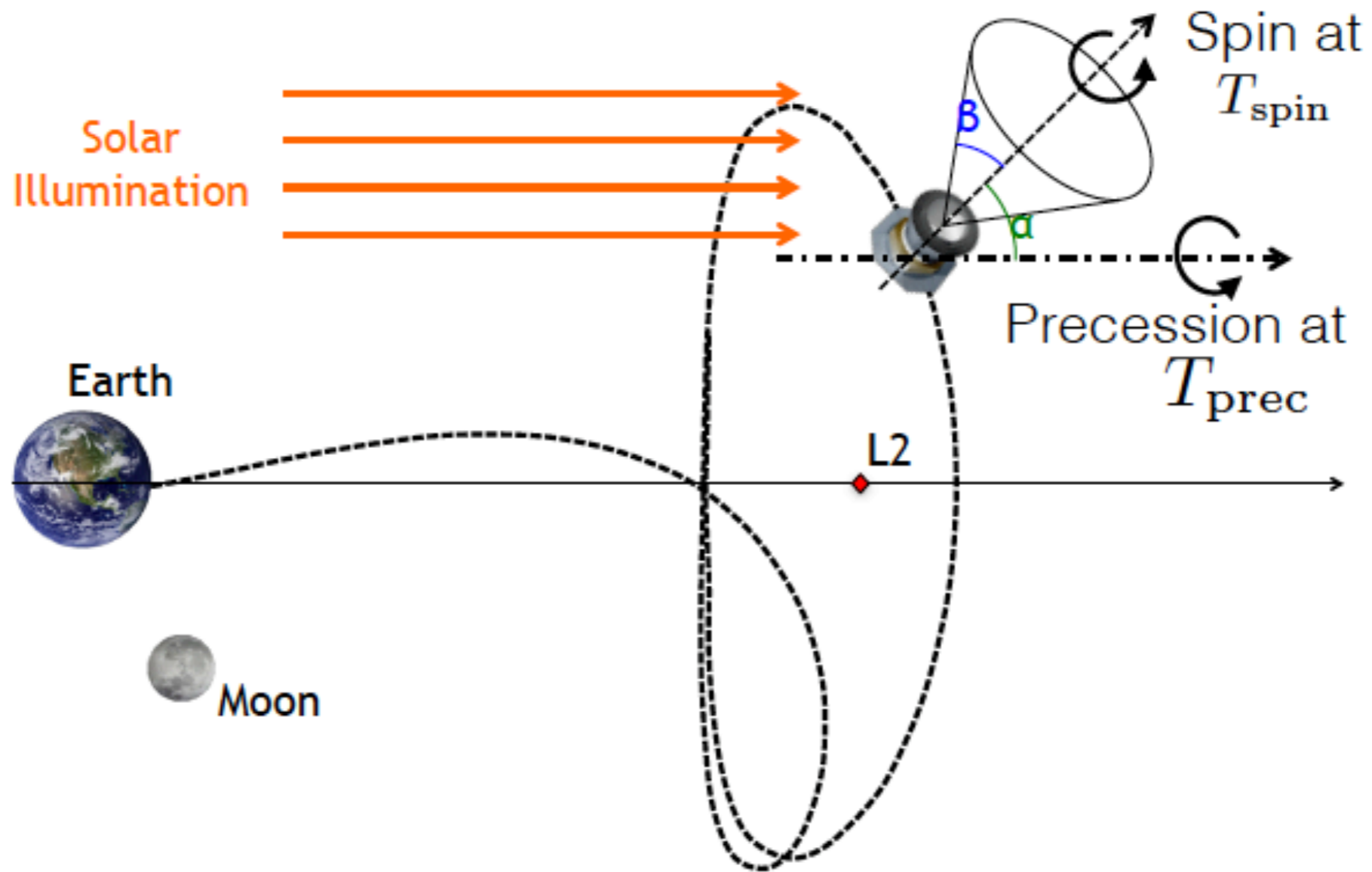

Cross dragone, aperture = 1.4 m (EPIC-IM)

$\alpha = 22 \text{ deg}$, $\beta = 78 \text{ deg}$

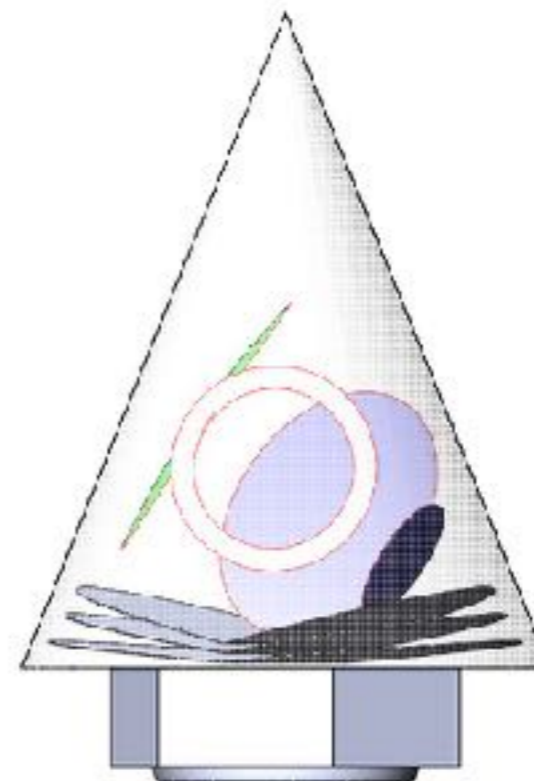
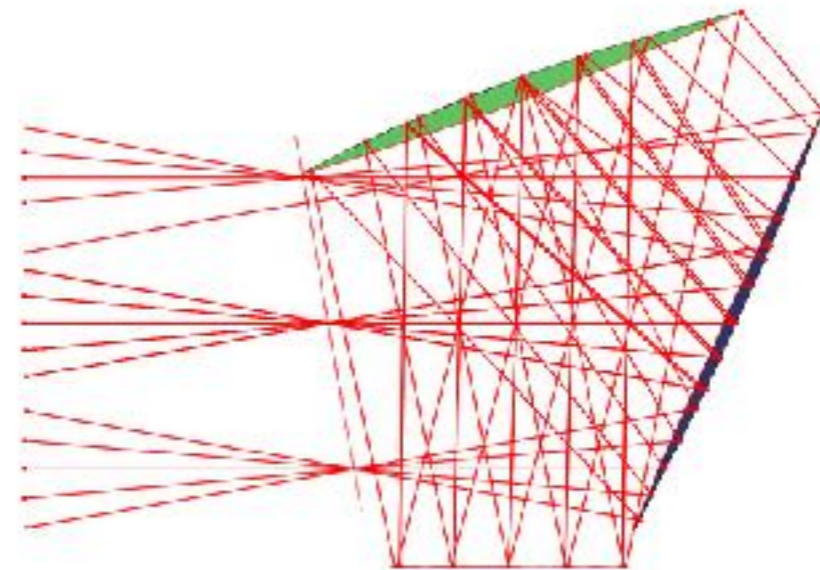
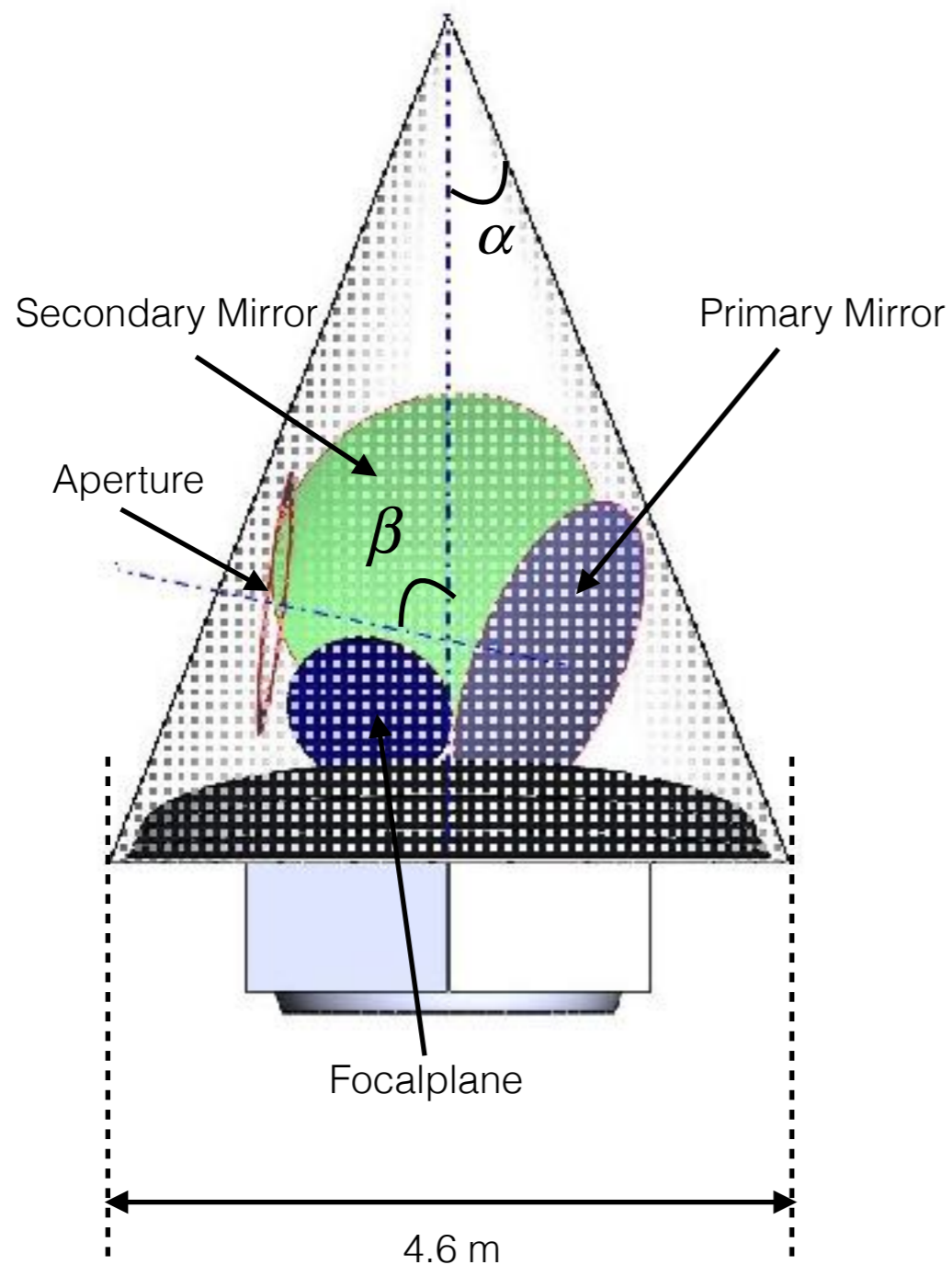

EPIC Cross-Dragone 1.4 m

$A = 45^\circ$

$B = 55^\circ$

1.1m extendable shields allow $A = 45^\circ$

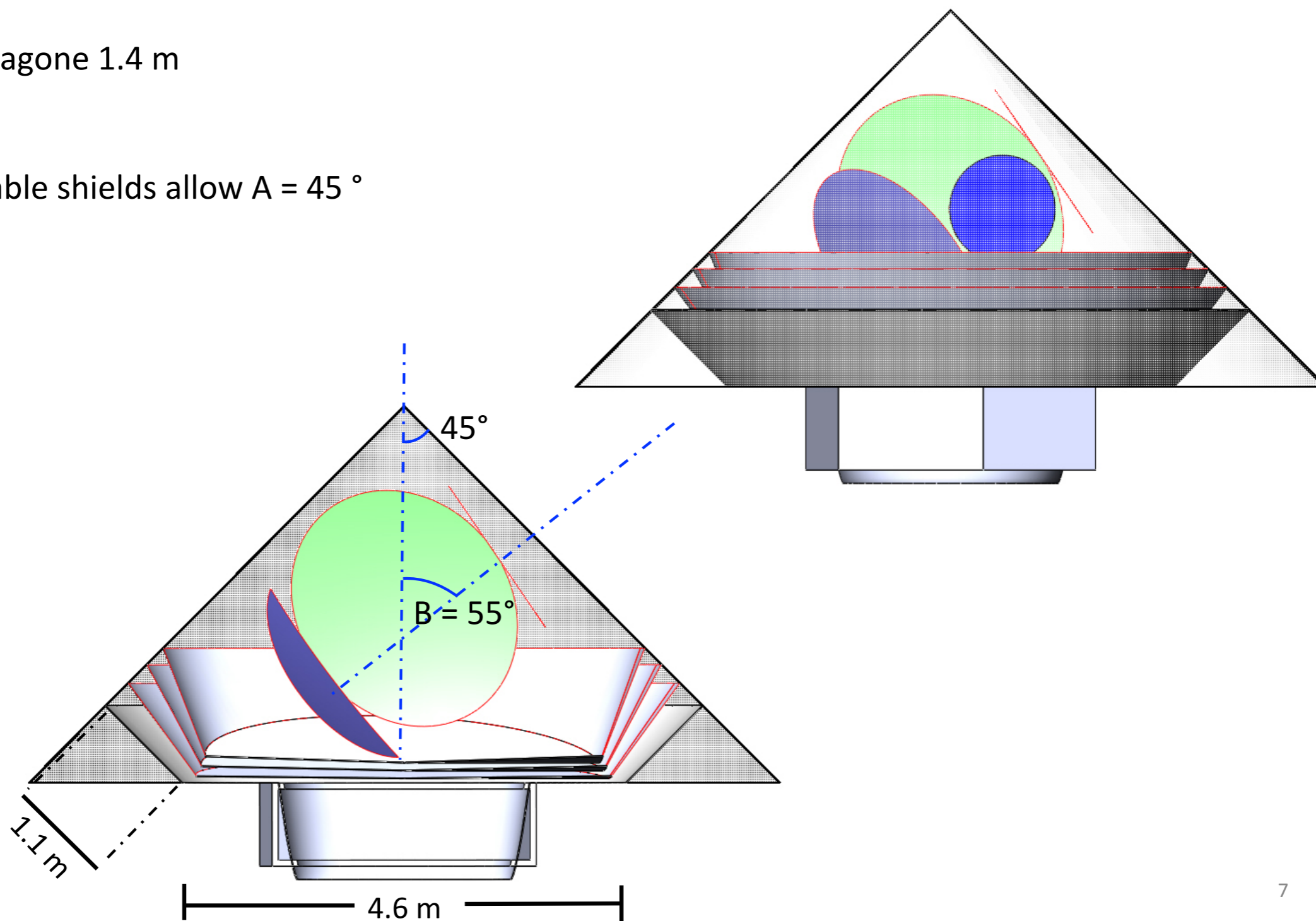

Cross Dragone

Aperture / m	a / deg	β / deg	$a+\beta / deg$
1.0	36	64	100
1.2	30	70	100
1.4	22	78	100
1.6	15	85	100

7 deg per 0.2 m diameter

Open Dragone (1.4 m)

Aperture / m	a / deg	β / deg	$a+\beta / deg$
Stop on Primary	31	69	100
Mid_stop	24	76	100
Three Mirrors	26	74	100

Cross dragone, aperture = 1.0 m
 $\alpha = 36 \text{ deg}$, $\beta = 64 \text{ deg}$

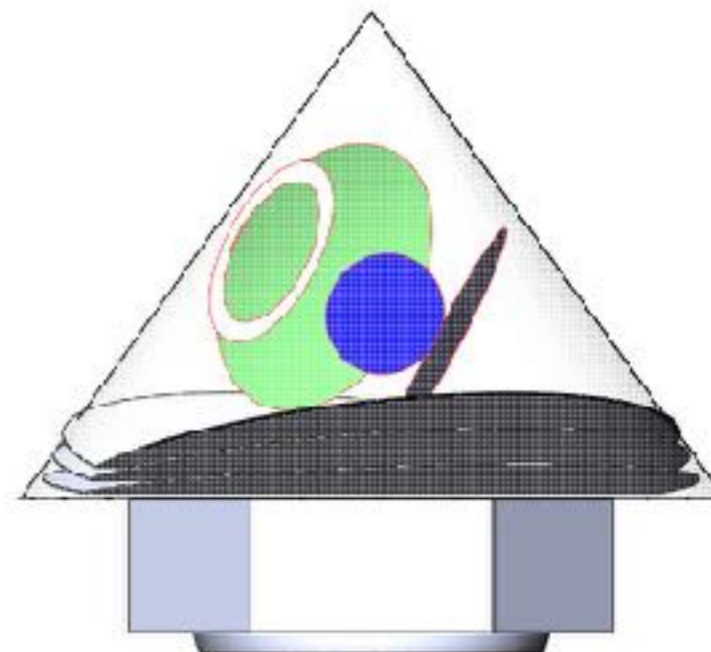
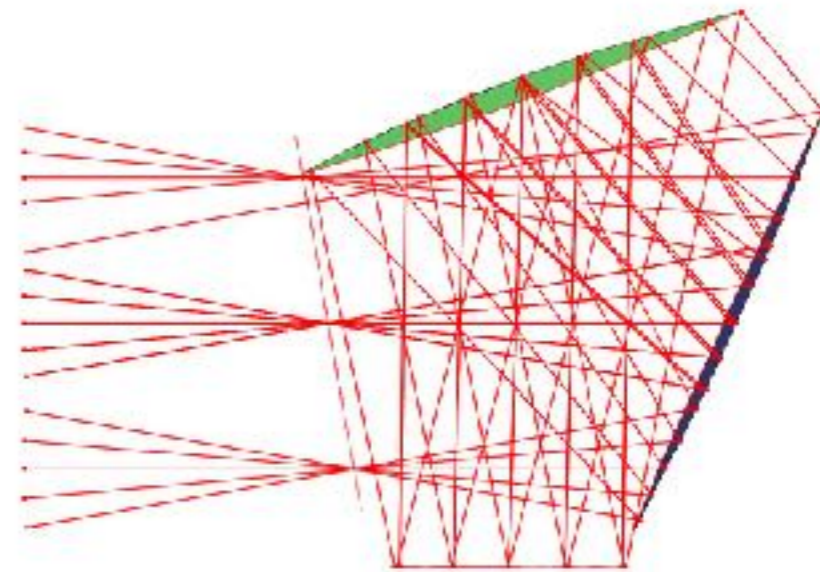
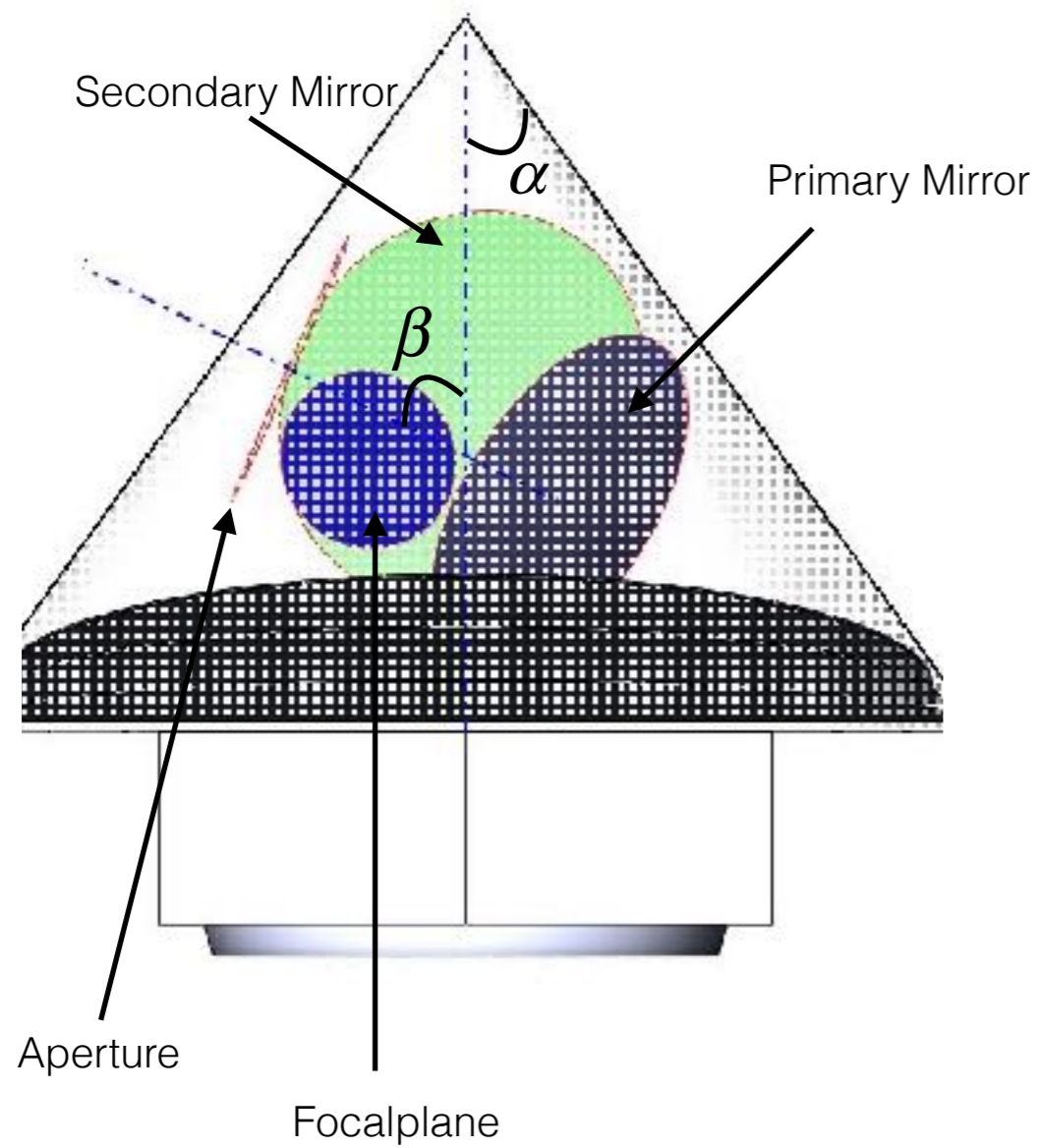

Cross dragone, aperture = 1.2 m
 $a = 30 \text{ deg}$, $\beta = 70 \text{ deg}$

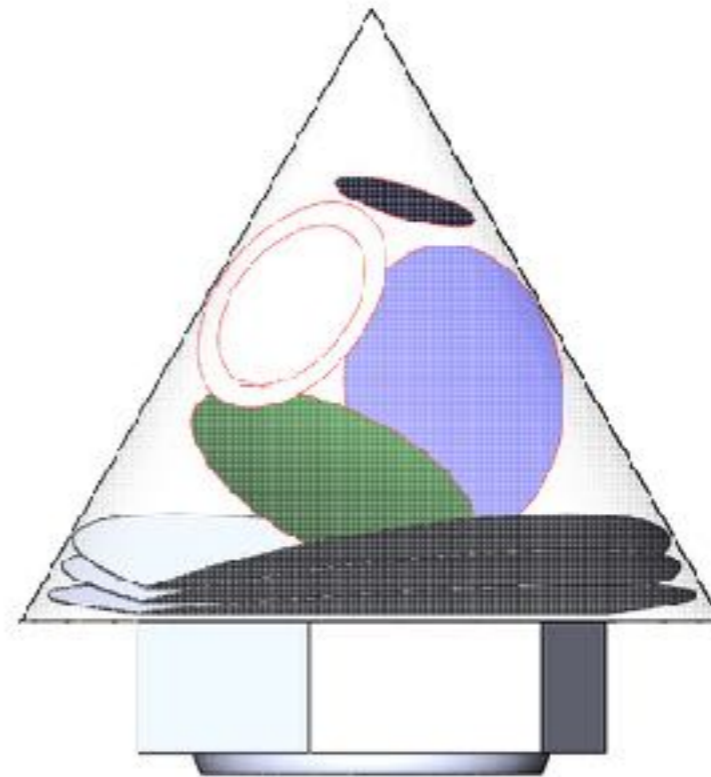
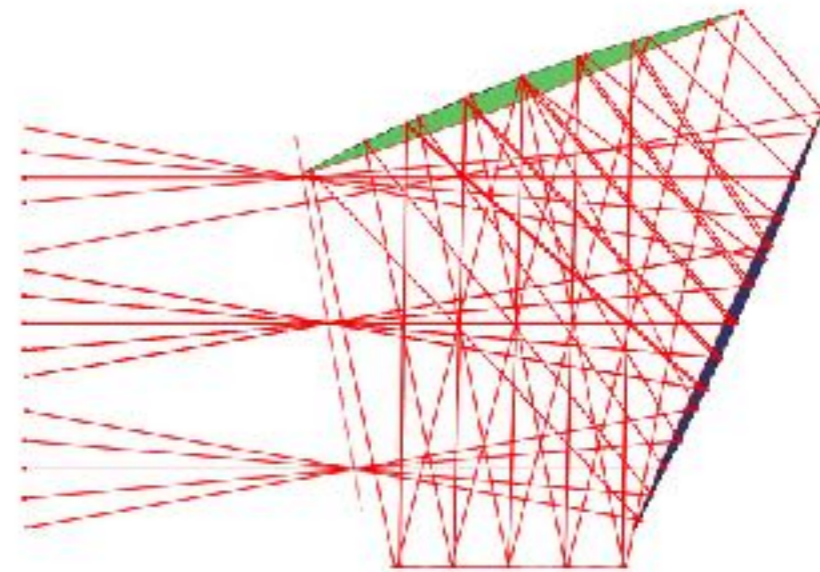
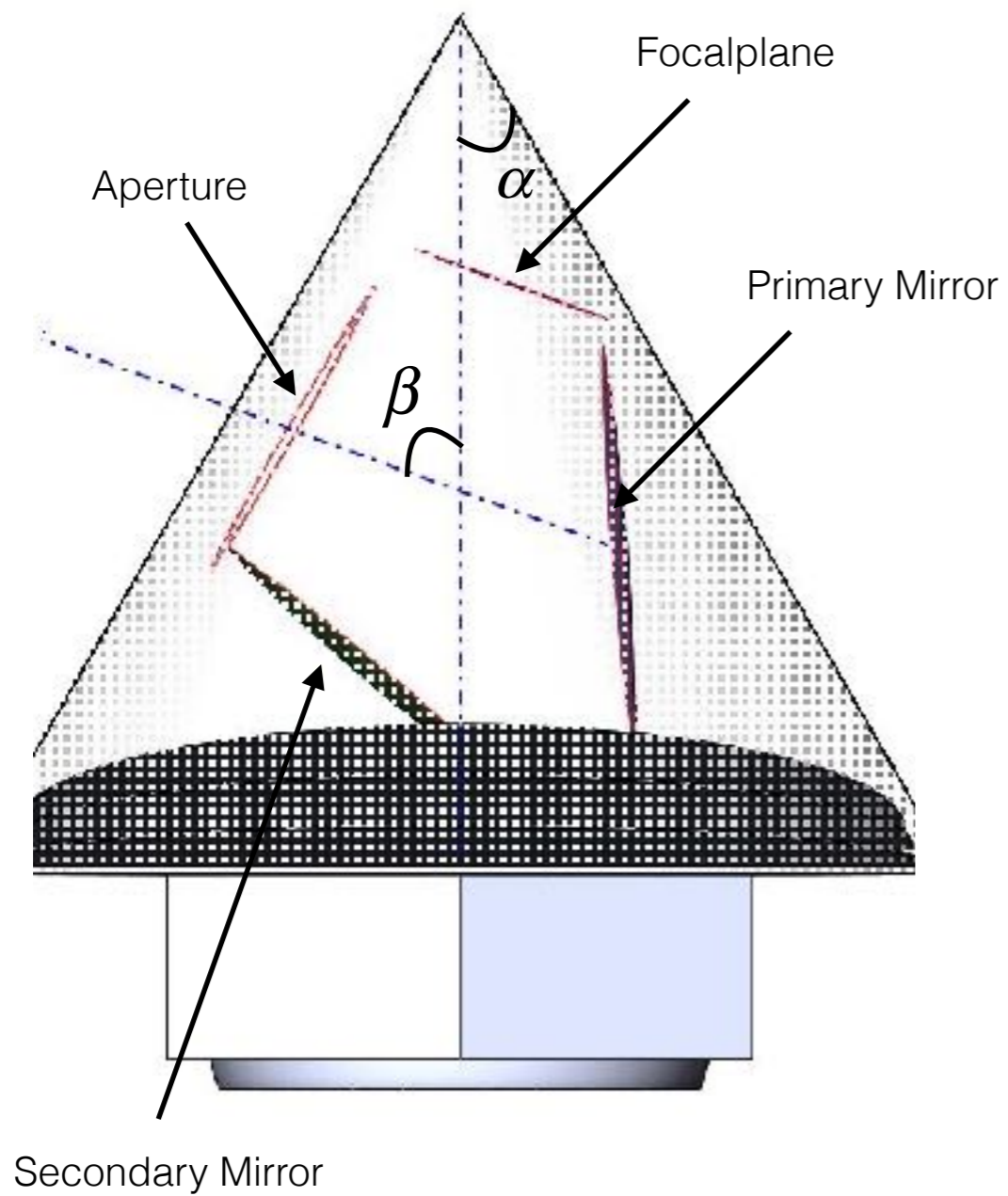

Cross dragone, aperture = 1.6 m
 $\alpha = 15 \text{ deg}$, $\beta = 85 \text{ deg}$

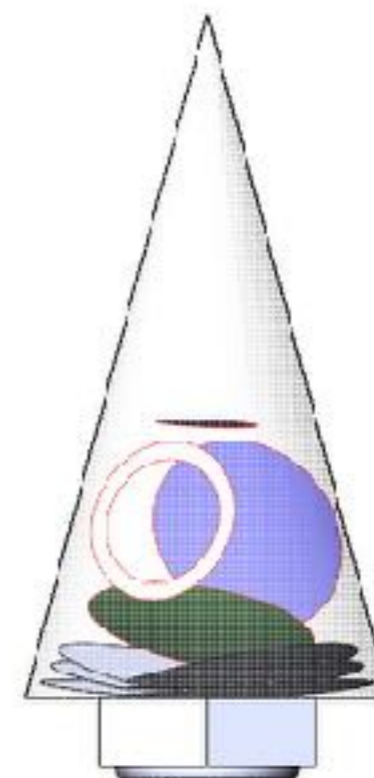
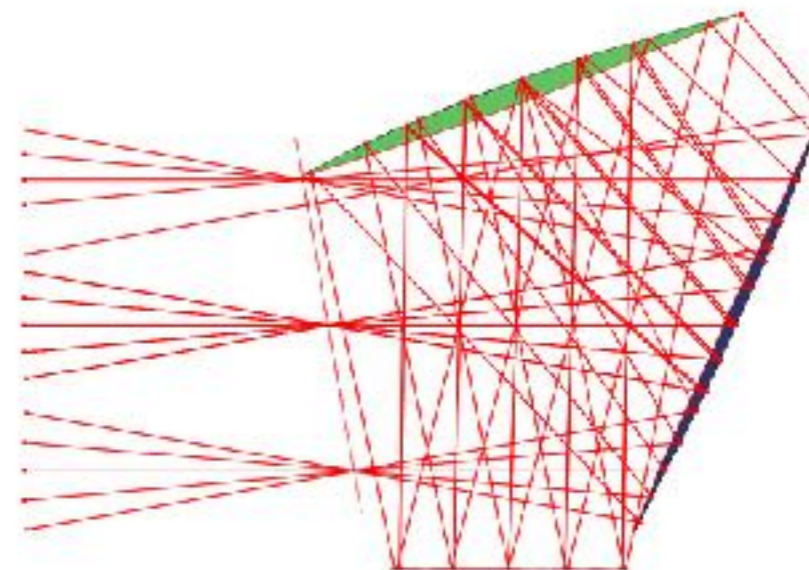
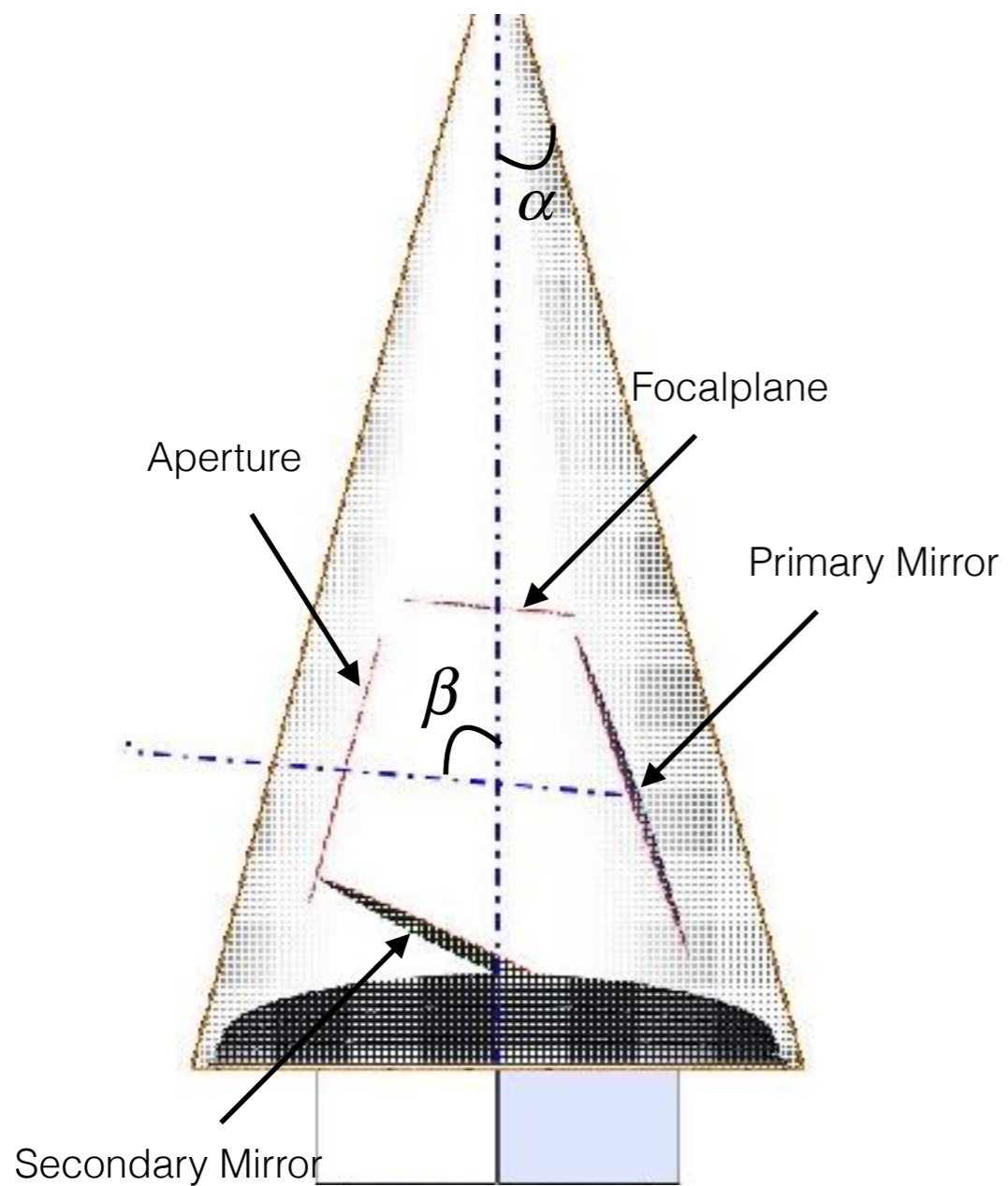

Open dragone, **stop at primary mirror**, aperture = 1.4 m
 $a = 31 \text{ deg}$, $\beta = 69 \text{ deg}$

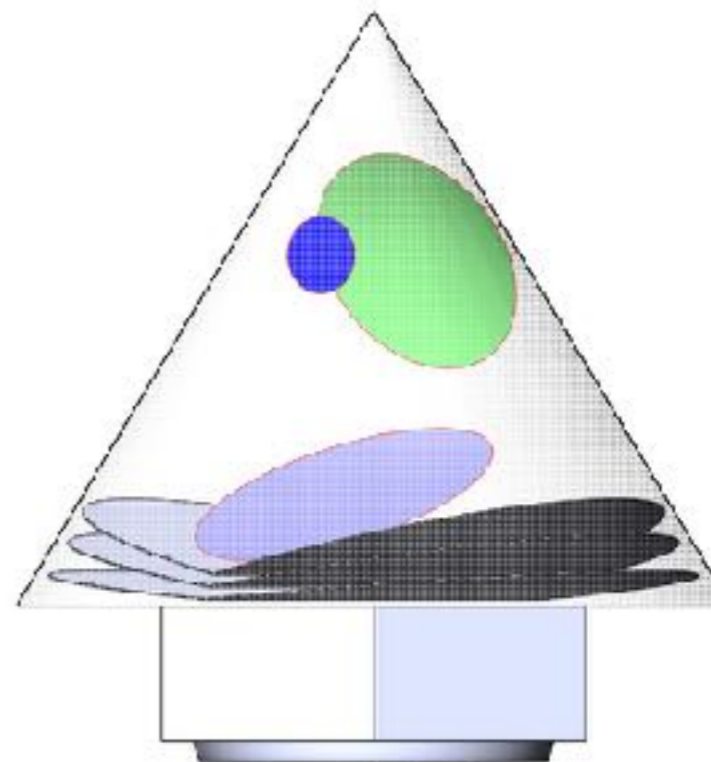
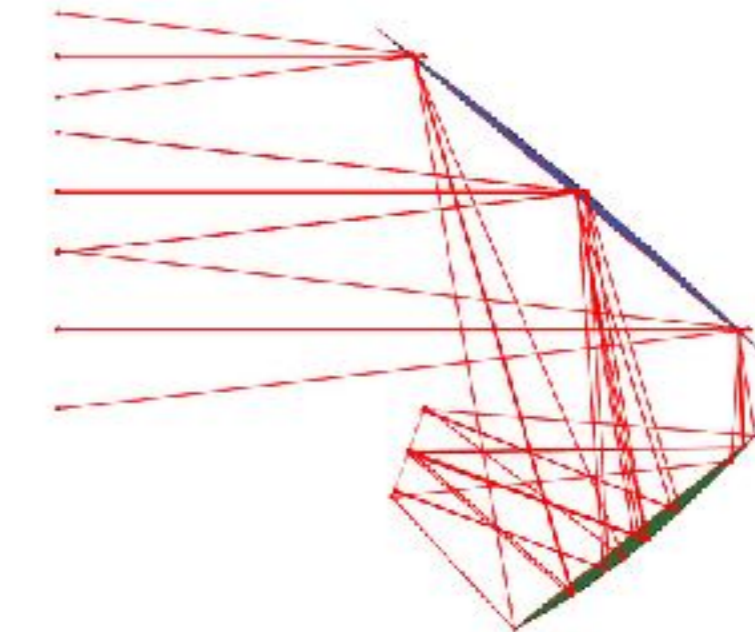
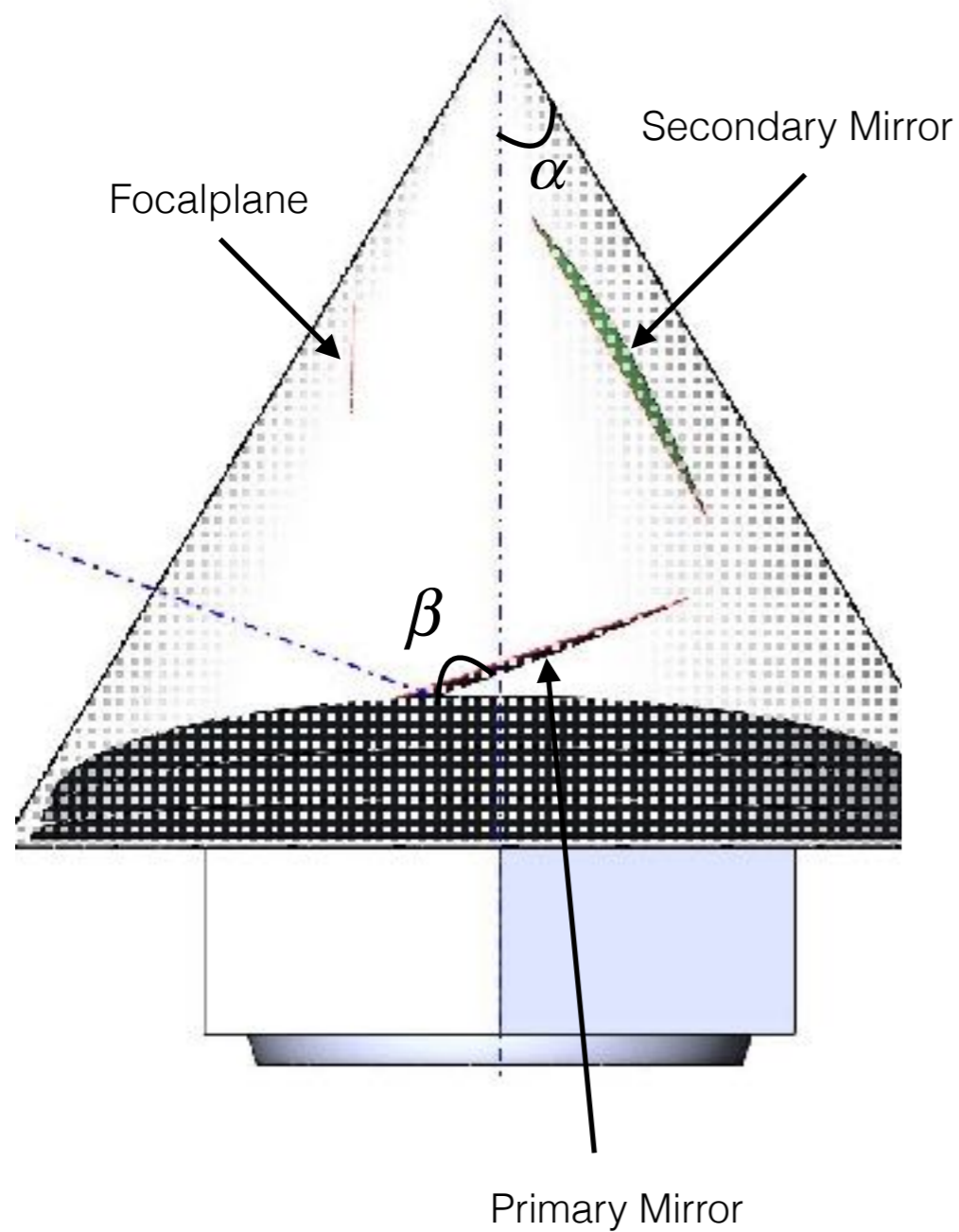

Open dragone, **stop between mirrors**, aperture = 1.4 m
 $\alpha = 24 \text{ deg}$, $\beta = 76 \text{ deg}$

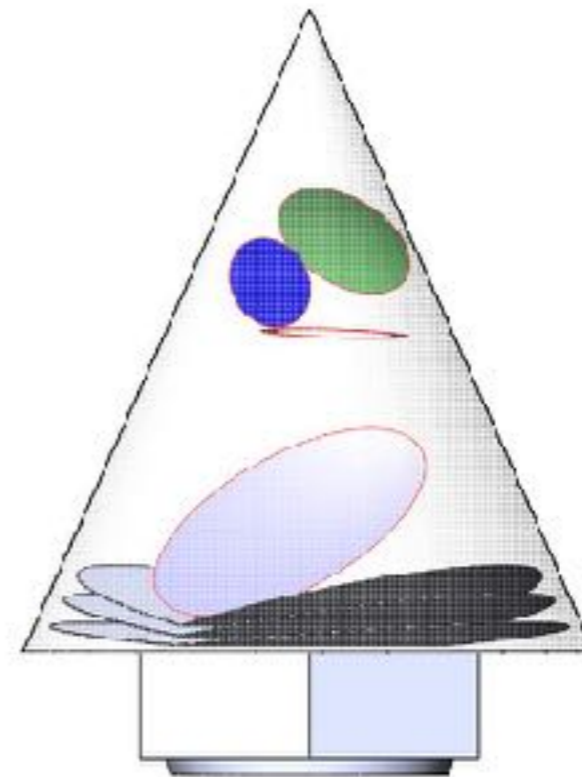
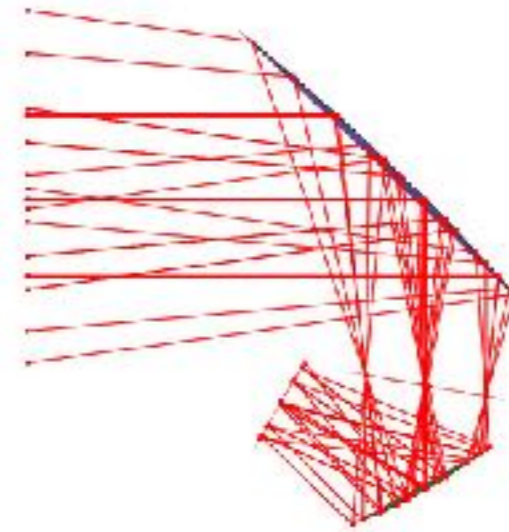
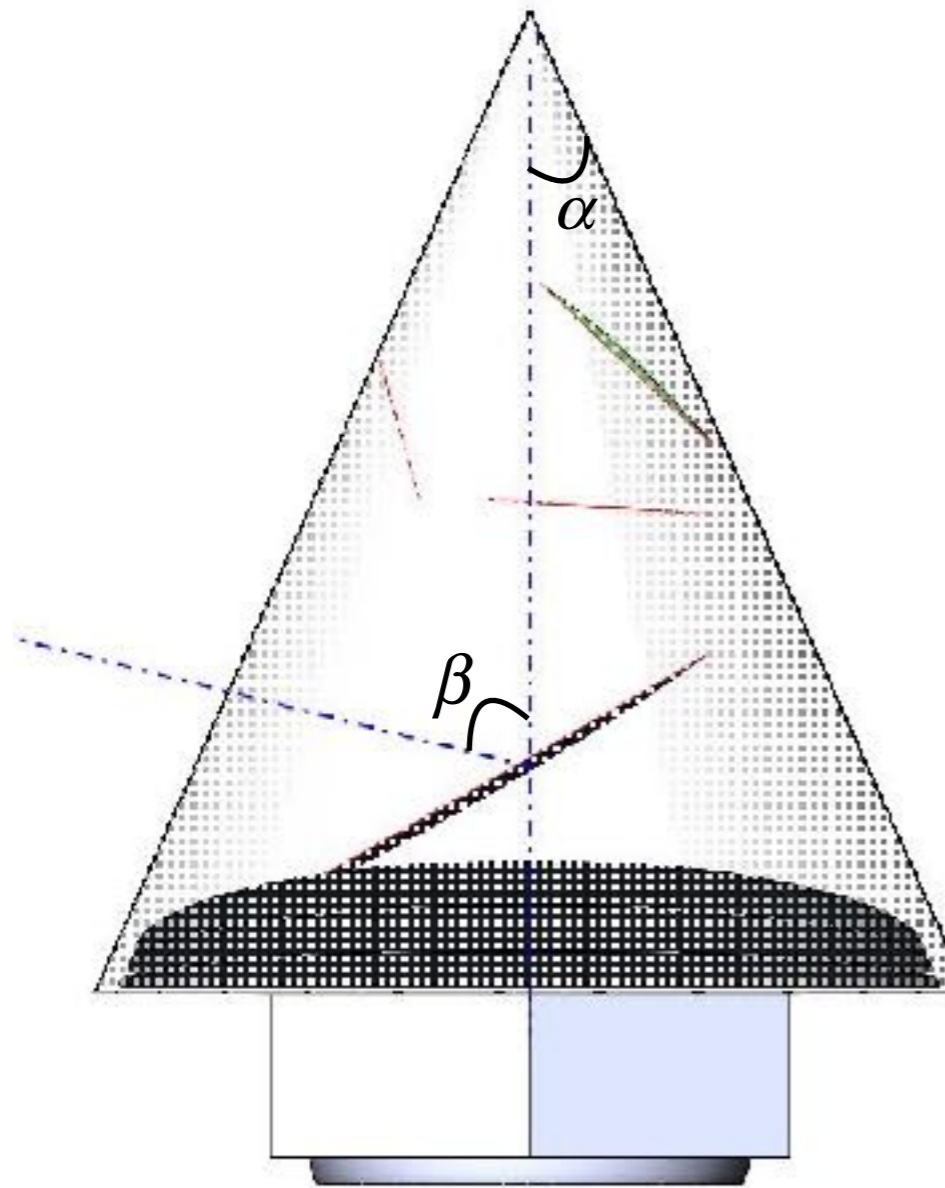

Open dragone, **fold mirror**, aperture = 1.4 m
 $a = 26 \text{ deg}$, $\beta = 74 \text{ deg}$

