

CMBP Imager

July 17, 2017

Background - I

- CMBP = Probe Scale CMB Polarization Mission Study
- Probe Scale = \$400M - \$1000M
- Mission study + cost estimate + independent cost estimate to be submitted to decadal panel.
 - JPL is our partner for the mission engineering
- Overall goals
 - convince decadal that there is worthy astrophysics science in this cost range
 - have CMBP rank high in overall prioritization

Background - II

- CMBP Instruments
 - Imager - this group
 - Spectrometer - spectrometer group
 - Combined mission - spectrometer group
- Goals of this group:
 - provide input for the design of the imager;
 - take part in quantitative trade-off studies, if necessary

Imager Starting Points

- EPIC-IM and CORE
 - 1706.04516
 - 1705.02170
 - 0906.1188
 - links to papers on wiki page

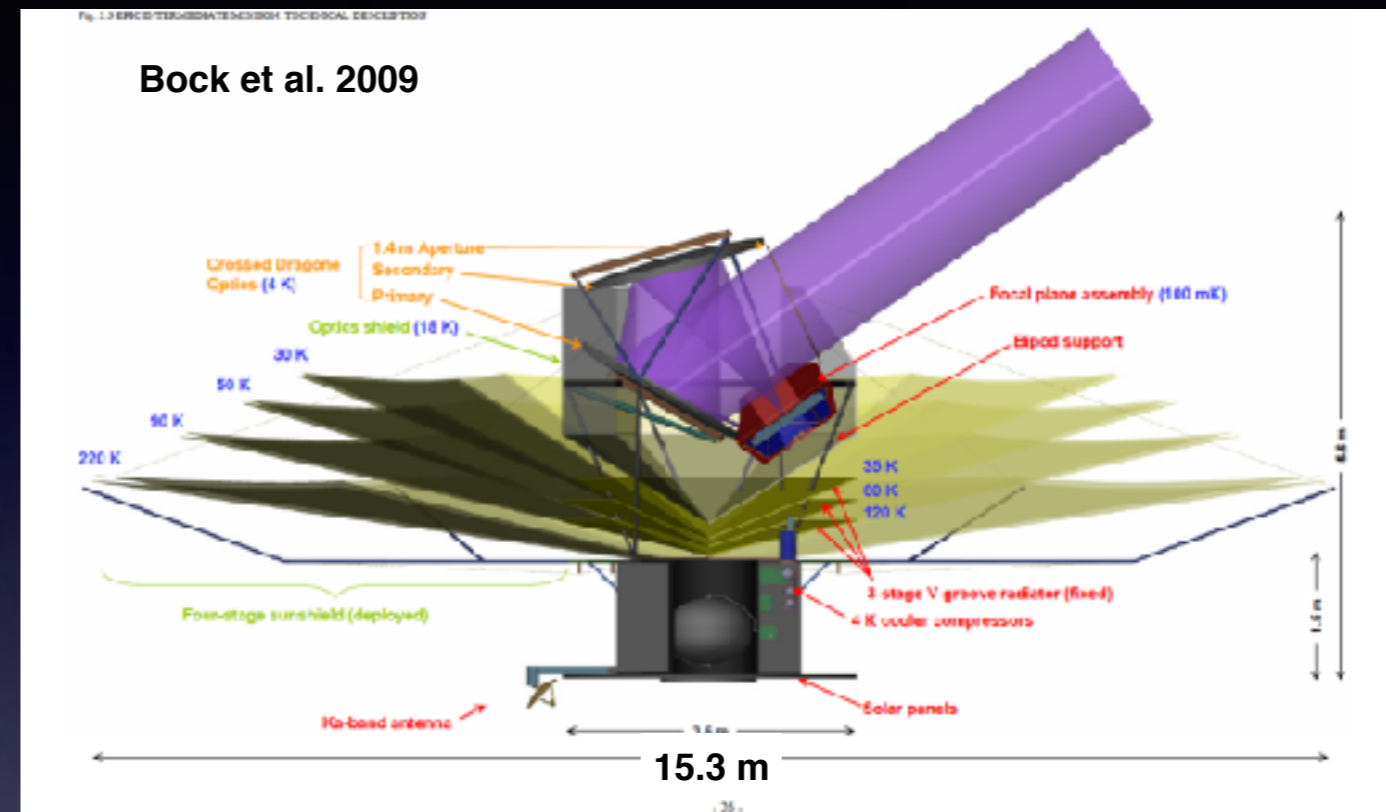

delabrouille et al. 2017

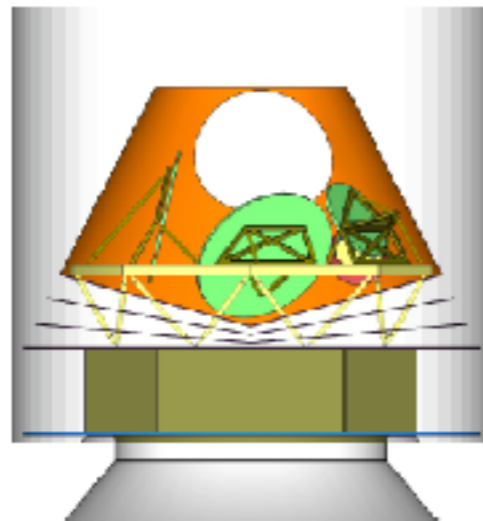
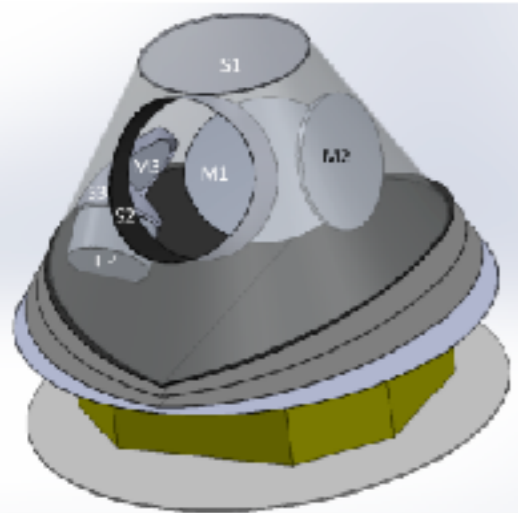

delabrouille et al. 2017

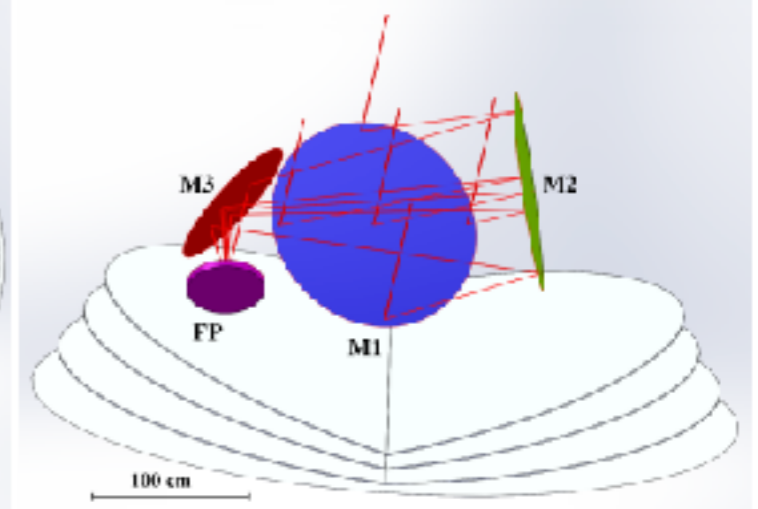
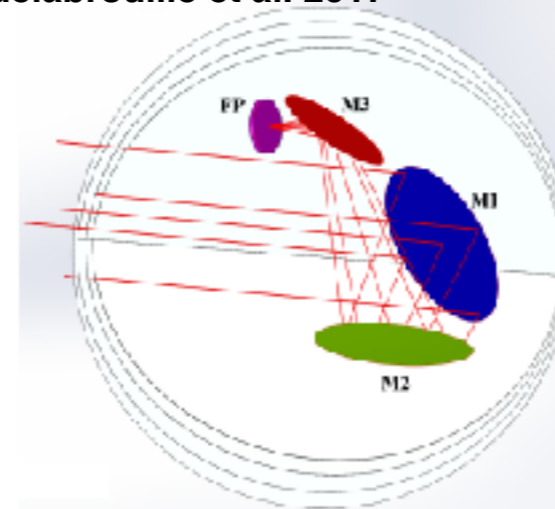

CMBP Starting Assumptions

- Medium aperture (>0.5 m)
- Reflector based
- TES-based + Muxed readouts
- Any comments before we proceed?
- Next few slides = telescope; Other specific topics to discuss in the future?

Telescope Trade-offs - I

- Three 1.2 m systems reported in CORE instrument paper
- Drivers:
 - focal plane shape and area
 - focal plane view of the sky (see slide 4)

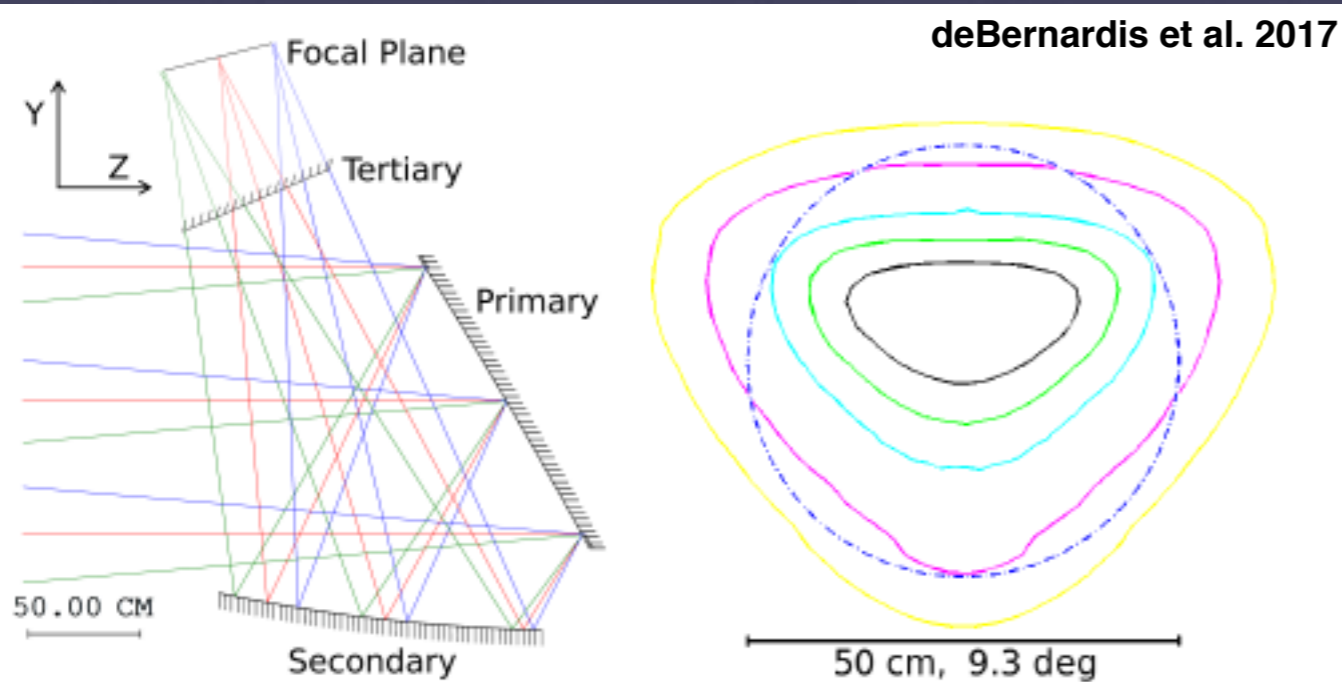
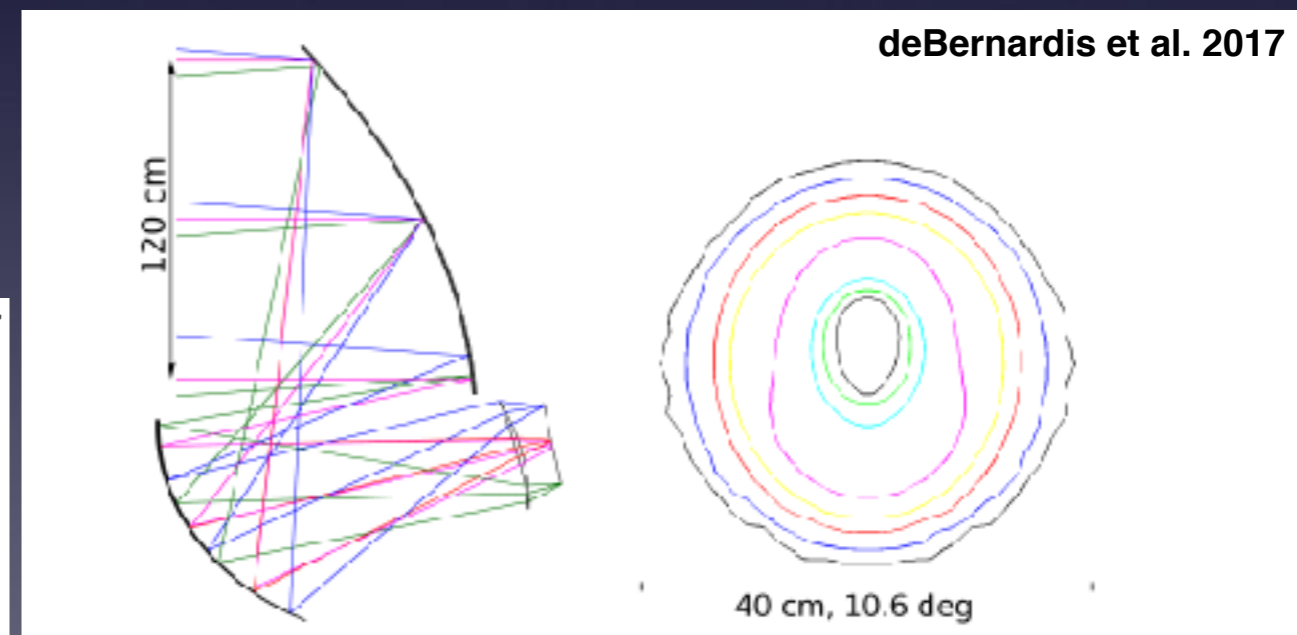
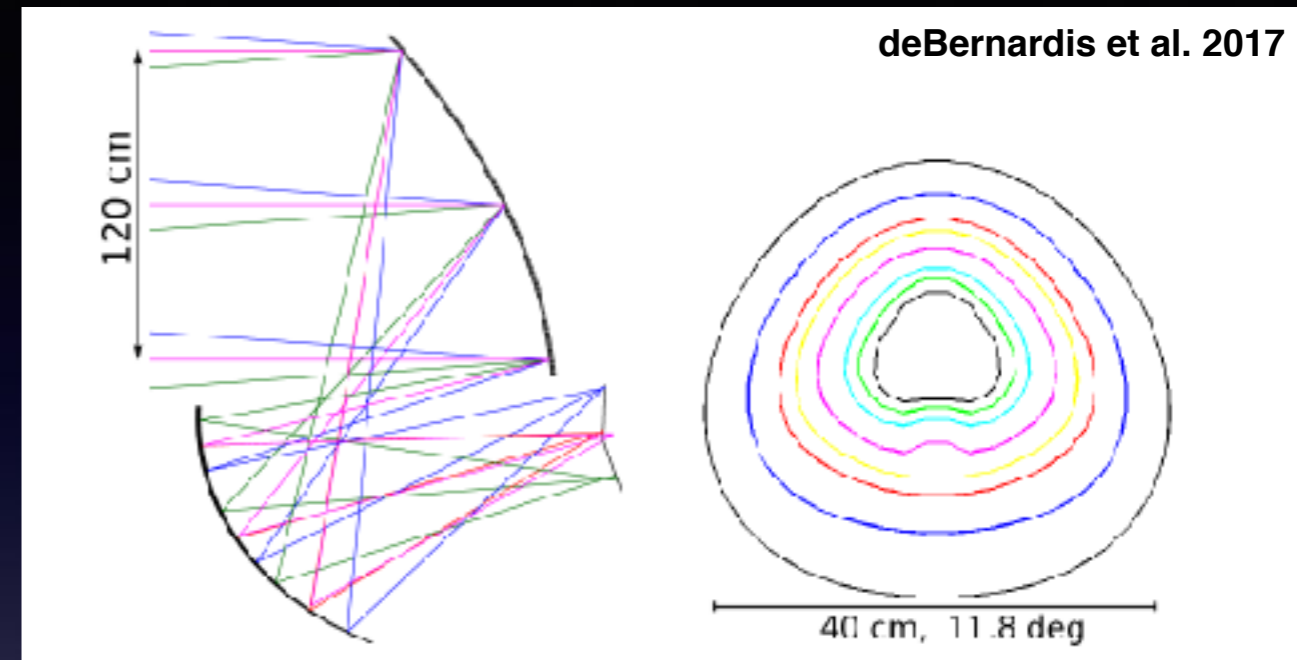

Telescope Trade-offs - II

- Reviving the EPIC-IM design: see ppt slides posted
- How important is it to avoid direct view of sky?

Telescope Trade-offs - III

- Open Dragone
- Pros/Cons:
 - can baffle focal plane
 - larger reflectors -> packing challenge?

Book et al. 2009

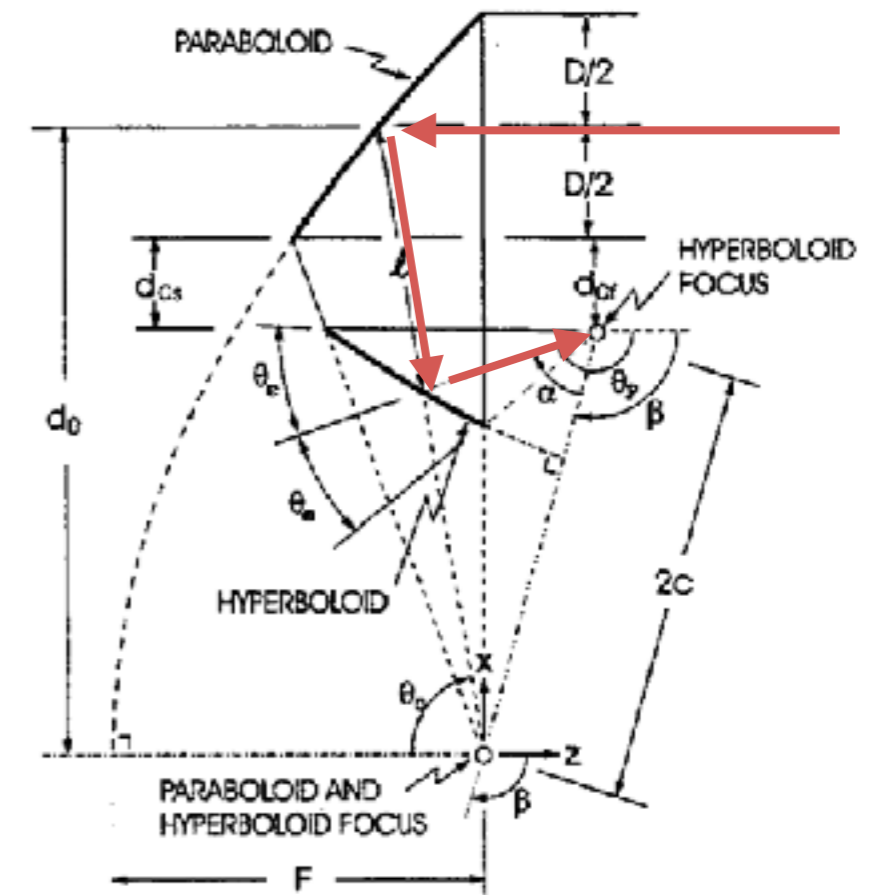
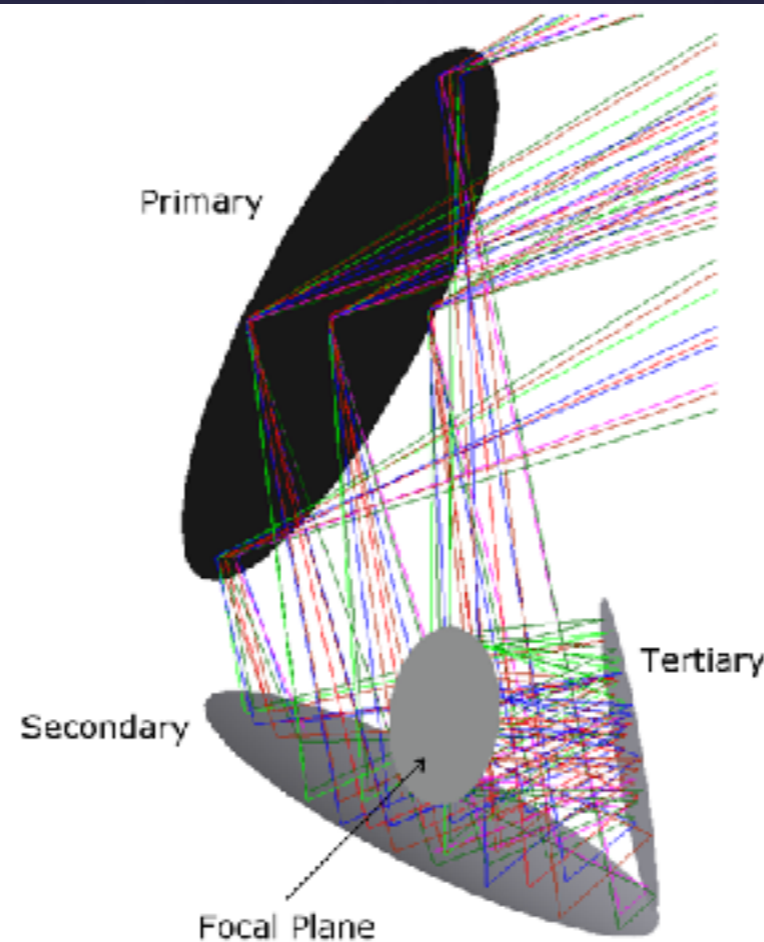
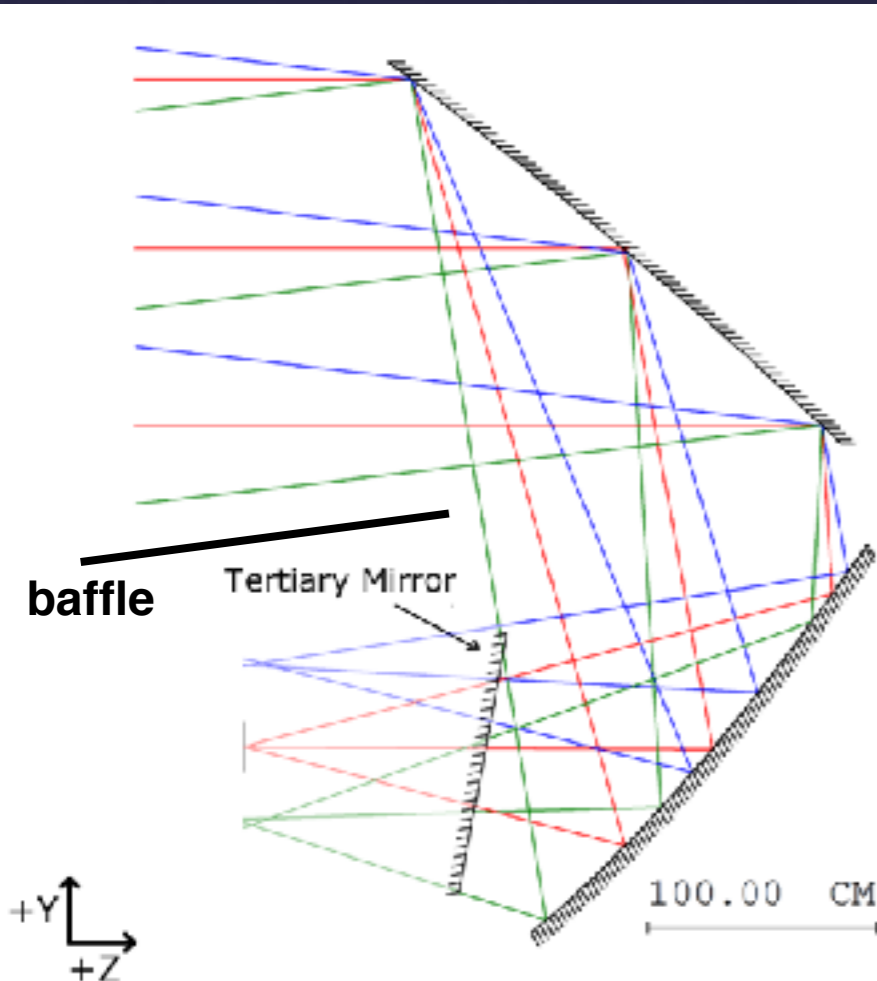

Backup Slides